

Worksheet 9.5 Composite Transformations Prep Name _____

Graph the image of $A(1, -3)$ after the described glide reflection.

- 1) Translation: $(x, y) \rightarrow (x + 2, y)$ 2) Translation: $(x, y) \rightarrow (x - 4, y + 3)$ 3) Translation: $(x, y) \rightarrow (x - 3, y + 2)$
 Reflection: in the x -axis Reflection: in $y = 2$ Reflection: in $x = 2$

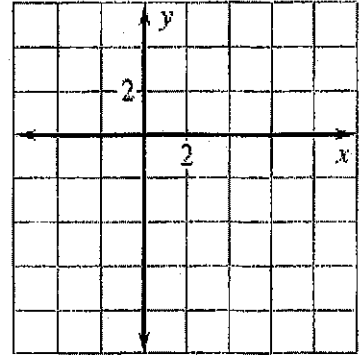
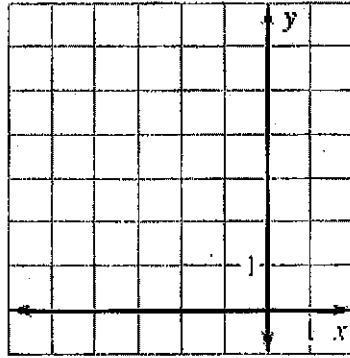
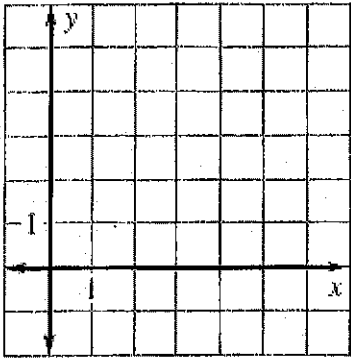

The endpoints of \overline{CD} are $C(1, 2)$ and $D(5, 4)$. Graph the image of \overline{CD} after the glide reflection.

- 4) Translation: $(x, y) \rightarrow (x - 4, y)$
 Reflection: in x -axis

- 5) Translation: $(x, y) \rightarrow (x, y + 2)$
 Reflection: in $y = x$

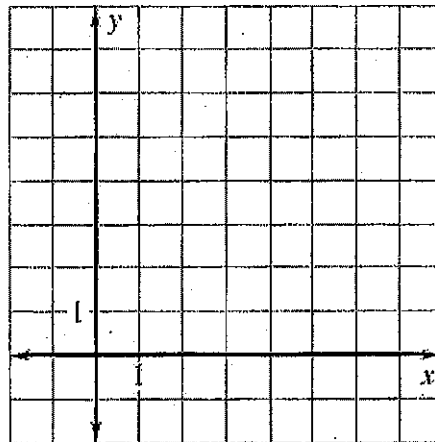
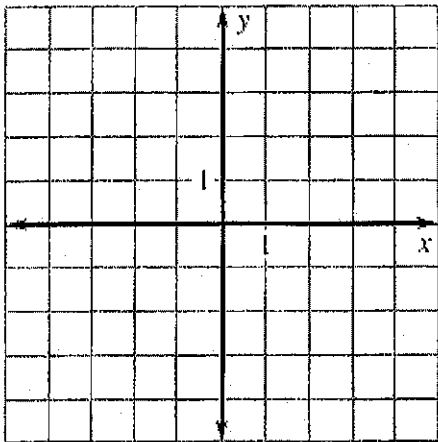

Describe the composition of the transformations.

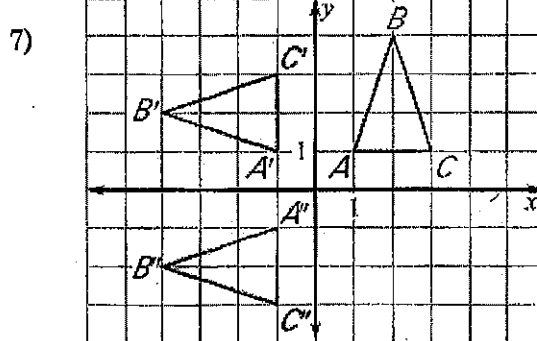
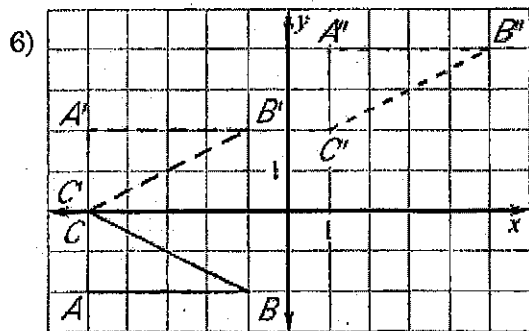

The vertices of $\triangle ABC$ are $A(2,4)$, $B(7,6)$, and $C(5,2)$. Graph the image of $\triangle ABC$ after a composition of the transformations in the order they are listed.

- 8) Translation: $(x,y) \rightarrow (x-4,y-3)$
 Reflection: in the x -axis

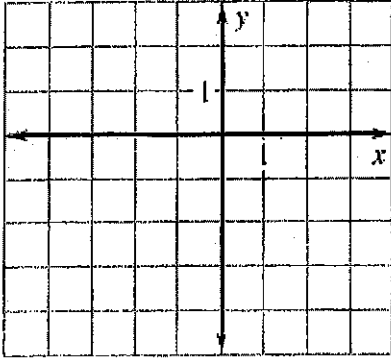

- 9) Translation: $(x,y) \rightarrow (x-2,y)$
 Rotation: 90° about the origin

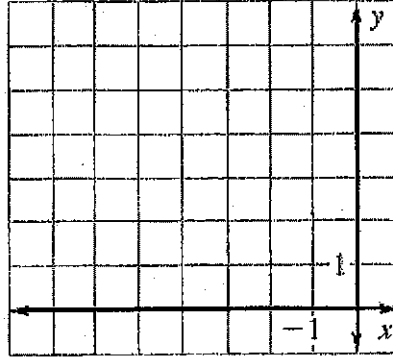

The vertices of $\triangle ABC$ are $A(3,1)$, $B(1,5)$, and $C(5,3)$. Graph the image of $\triangle ABC$ after a composition of the transformations in the order they are listed.

- 10) Translation: $(x,y) \rightarrow (x+3,y-5)$
 Reflection: in the y -axis

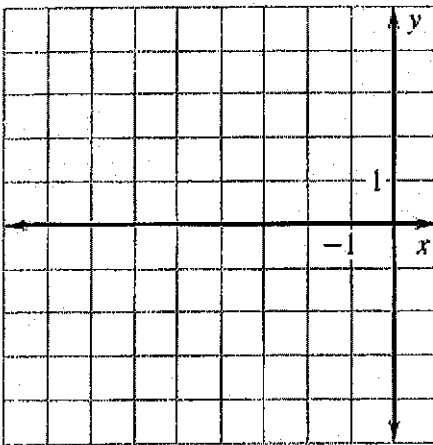

- 11) Translation: $(x,y) \rightarrow (x-6,y+1)$
 Rotation: 90° about the origin

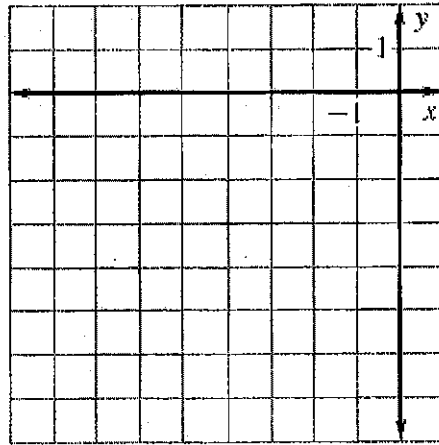

Match the composition with the diagram.

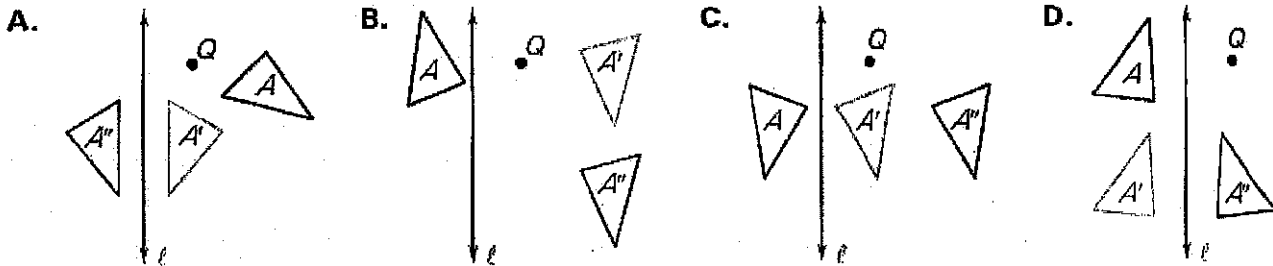

- 12) Translate parallel to ℓ then reflect in ℓ . 13) Rotate about Q , then translate parallel to ℓ .

- 14) Rotate about Q , then reflect in ℓ . 15) Reflect in ℓ , then translate perpendicular to ℓ .

Compositions

①

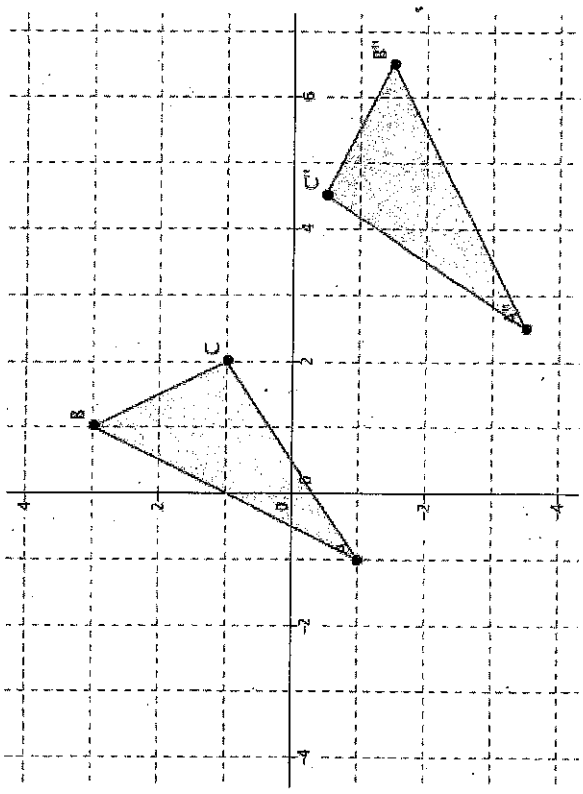

③

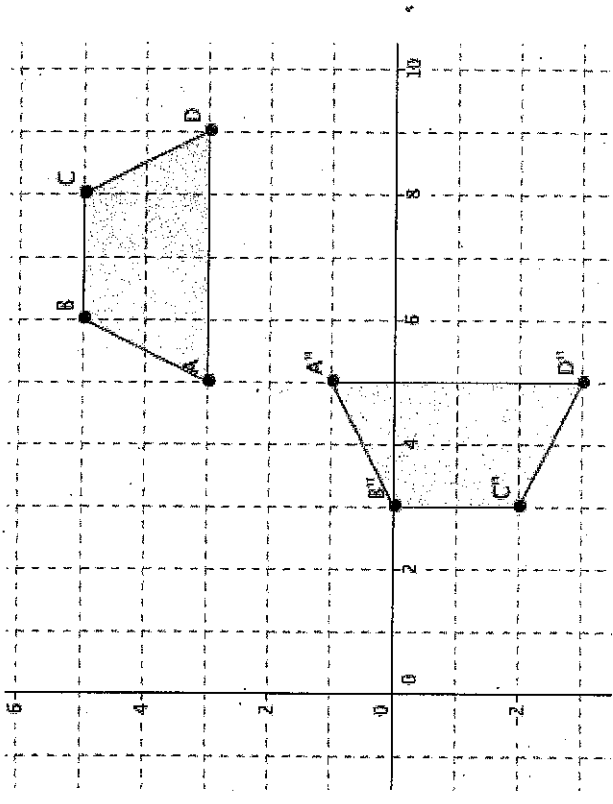

②

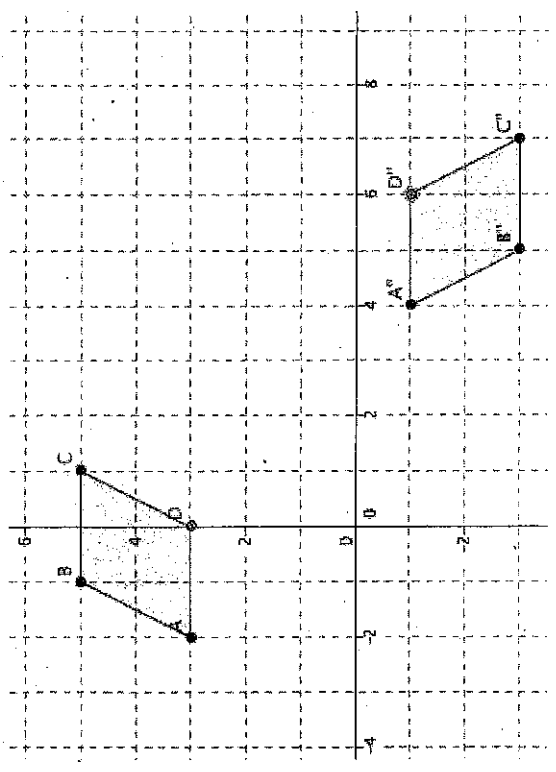

④

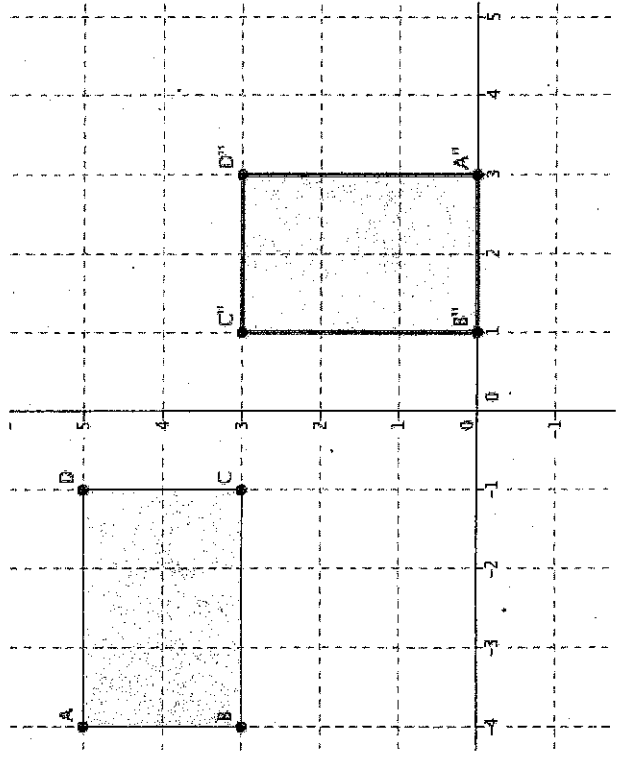

5

